

ORION

Combination

ORION DRY-PUMP

-Oil-less Rotary Vane Vacuum Pump and Blower-

Instruction Manual

CBX15

CBX25

CBX40

CBS62

CBX62



 **ORION MACHINERY CO., LTD.**

INTRODUCTION

Thank you very much for buying the ORION "COMBINATION" Dry Pump.

The ORION Combination Dry Pump operates without oiling or greasing. When used as a blower, it can supply clean, compressed dry air; and when used as a vacuum pump, the exhaust does not contain any oil vapors.

As opposed to conventional oil type pumps, this dry pump can be used for a wide range of applications because no impurities are imparted to liquids or solids processed with this pump.

In addition to the precautions, description of the construction and operating procedures necessary for the operation of the pump, this instruction manual provides troubleshooting procedures and matters concerning maintenance and inspection of the pump in an easy-to-understand manner.

For normal operation of this Dry Pump, carefully read this manual and observe the instructions concerning the operation, operating procedure, maintenance and inspection.

- For proper use of the ORION Dry Pump and Blower, read this instruction manual carefully and thoroughly.

CONTENTS

SAFETY PRECAUTIONS	1
Always observe these for safety reasons	2
PLACE WARNING AND CAUTION LABELS ON THE PUMP BODY.....	3
1 PROMINENT FEATURES	5
2 BEFORE USING.....	5
1. INSPECTION	5
2. PREPARATIONS	5
3. OPERATION	7
4. STORAGE.....	7
3 CONSTRUCTION AND NAMES OF PARTS	8
4 TROUBLESHOOTING.....	9
1. TROUBLE DIAGNOSIS AND REMEDY	9
2. DISASSEMBLY PROCEDURE.....	10
3. ASSEMBLY PROCEDURE	12
5 PERIODIC INSPECTION.....	13
1. CLEANING OF FILTER	13
2. CLEANING OF VACUUM CONTROLLER AND PRESSURE CONTROLLER	13
3. INSPECTION OF PIPING.....	13
4. INSPECTION OF PUMP BODY.....	13
5. INSPECTION OF V-BELT.....	14
6 SPECIFICATIONS	16

Place of Warning and Caution labels on the pump body

Precautions regarding installation



Indicates a potentially hazardous situation which, if not observed, may result in injury of operator or physical damages.

Do not put your hand inside the covers
Do not put your hand inside the belt, coupling or fan covers, or it could result in severe injury such as cutting of your hands or fingers.

Do not operate the electric motor over the rated power source
Do not operate the electric motor over the rated power source, or it could result in troubles.

Do not place objects on the pump
Do not put heavy objects or containers filled with water on the pump or motor. Injuries could result from objects falling off the equipment, and spilled water could cause a short circuit, rust or electric shock if the electrical insulation is damaged.

Do not touch the surface of the equipment while it is hot
Do not touch the surface of the pump, motor or pipes as it becomes very hot. Touching the surface while the equipment or pipes are hot can result in burns.

Periodically inspect the circuit breaker
Operation of the circuit breaker should be inspected periodically. Using the pump with a faulty circuit breaker can result in electric shock if a short circuit occurs.

Install the check valves
Check valves should be installed to protect the pump if it runs in reverse due to residual pressure when the pump stops. The pump may be damaged or injuries can result if the check valves are not installed.

Disconnect the power supply if the pump is not used for a long time
If the pump is not used for a long period of time, disconnect the power supply plug from the outlet for safety reasons. If it is not disconnected, a short circuit or electric shock can result.

Grasp the power supply cord firmly by the plug to disconnect it
When unplugging the power supply plug, grasp the plug, and not the cord. Pulling on the cord to disconnect it can snap some of the wires and resulting in heat generation or fire.

The following labels, selected as the most important one from the other warnings or cautions, stuck on the pump body. Read them surely before its operation.

Replace them with new one when their surfaces are hard to read due to stains or scratches. On the new labels, please contact your local pump distributor,

■ Scald



■ Electric shock

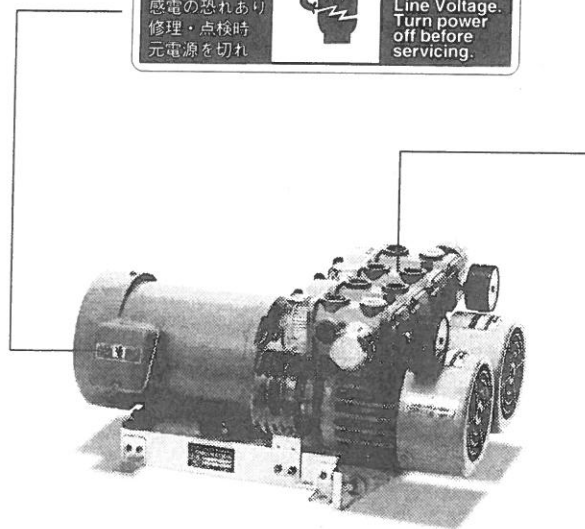
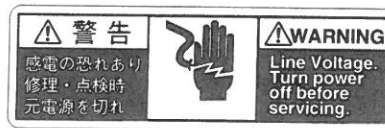

MODEL CBX25

Observe the following terms without fail

1. Hold the ambient temperature around the pump less than 40°C .
2. Prevent oil, water, dust and the like from entering or hitting the pump.

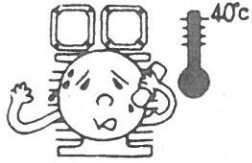

3. Do not apply any excessive pressure more than the necessary.

Model CBX, CBS □ Type using V_1 and B_2

V_1 : degree of vacuum, lower than 60 kPa ($\%$ —59, inHg—18)

B_2 : exhaust pressure, less than 60 kPa (bar—0.6, psi—8.5)

Model CBX, CBS □ **A** Type using V_1 , B_1 , V_2 and B_2

V_1 : degree of vacuum, lower than 55 kPa ($\%$ —54, inHg—16)

V_2 : degree of vacuum, lower than 35 kPa ($\%$ —34, inHg—10)

B_1 : exhaust pressure, less than 20 kPa (bar—0.2, psi—2.8)

B_2 : exhaust pressure, less than 50 kPa (bar—0.5, psi—7.1)

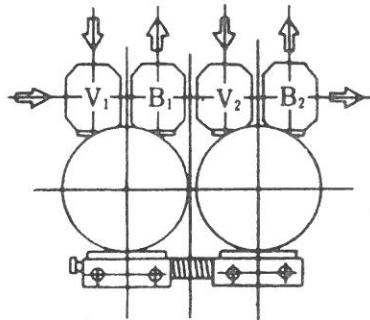

NOTE: These ranges are suggested operating ranges. The pumps will operate with more vacuum and more pressure but is suggested for only intermittent duty.

SECTION 1 PROMINENT FEATURES

- 1 Because of the 2 cylinders = 2 functions style (vacuum pump and blower arranged in parallel), the stability of each function and independent performance provide a long service life.
- 2 The ORION pumps have smaller dimensions and weight less than conventional combination pumps. One combination pump can be used as a vacuum pump or blower independently and each pump's function is separate from the other.
- 3 The range of applications are very wide because the pump is oil-less. It does not soil the environment of work or contaminate production material with oil because no oil is contained in the exhaust. It is best suited for printing and food processing industries, where oily air is prohibited.

SECTION 2 BEFORE USING

1. INSPECTION

Upon delivery, check the pump to ascertain the following:

- (1) No damage exists.
- (2) There is no loose nuts or bolts.
- (3) The shaft can be rotated smoothly by hand. (Check while keeping the suction or exhaust port open.)
- (4) The belts are tight.
- (5) No missing parts in the separately packaged accessories kit (gauge, controller, etc.).

2. PREPARATIONS

- (1) Recommended Site for Installation
 - 1) A well ventilated place of sufficiently low ambient temperature (below 40°C).
 - 2) A clean place free of dirt and dust.
 - 3) A place where no oil, water, etc. will fall on the pump.
 - 4) A place not exposed to direct sunlight.
 - 5) A place affording enough surrounding space for inspection, maintenance and disassembly work.
 - 6) Do not locate the pump in an atmosphere containing any corrosive gases, such as chlorine or sulfurous acid gas.
- (2) Installation
 - 1) Install the pump on a smooth, level surface.
 - 2) When utilization of the wooden framework used for packing is necessary, be sure to remove the wooden block.

※ Remove the wooden framework for packing. Especially, below mentioned wooden block can cause vibration and discrepancy of alignment, and can make abnormal noise and damage the belts.

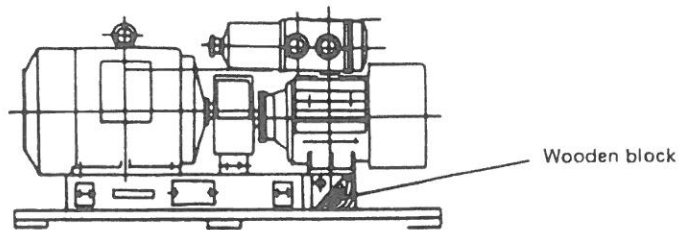

- 3) Make sure that the pump does not vibrate because of an imperfect foundation or unlevel surface.

(3) Piping

Plan View of Pump

See the attached case, at the top of the pump, from above.

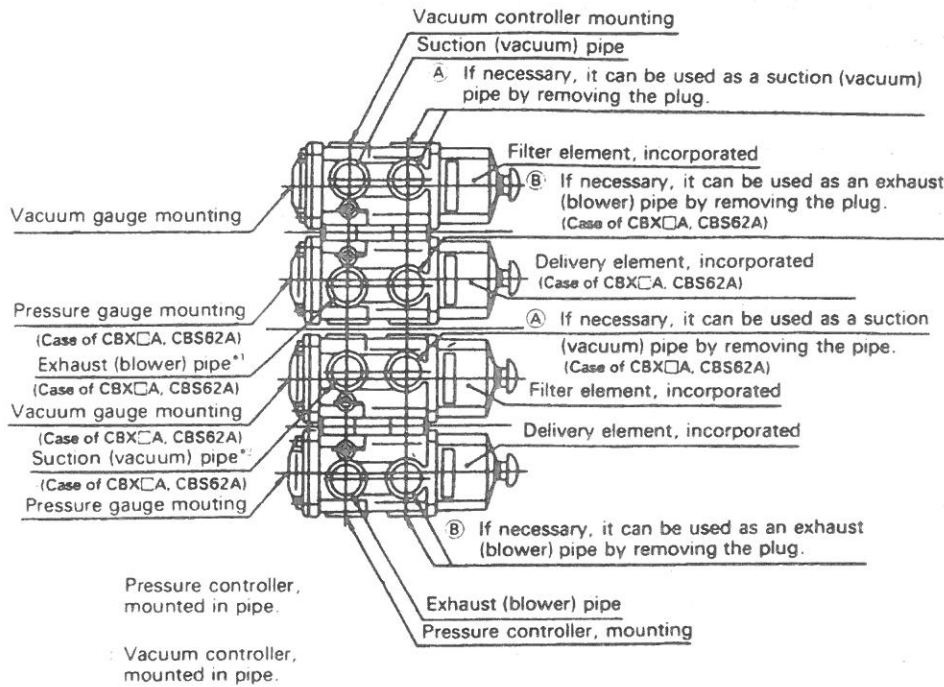

NOTES:

- Vacuum controller, pressure controller, vacuum gauge and pressure gauge may be mounted within the pipes, but be sure to locate the vacuum gauge and pressure gauge as close to the pump as possible.
- It should be noted that if you install the exhaust pipe from point B, the exhaust gas does not pass through the delivery element.

- 1) Install the supplied gauge and controller. Install carefully and correctly by referring to the above figure. Use proper tools (spanner or monkey wrench) for mounting.
- 2) Be sure to install the vacuum gauge and vacuum controller on the vacuum side and the pressure gauge and pressure controller on the exhaust side.
Additionally fasten the gauges till their faces come to horizontal between one and two rotation with proper tools after fastening gauges handtight.
※Excess tightness can cause crack to the delivery and suction case cap.
- 3) Arrange the piping as short as possible. Be sure that the piping does not make stress to the pump.
- 4) Use carbon steel pipe or pressure hose for the piping. If hose is used, securely fix the hose with hose clamps and make sure that the seal does not leak. If hose is employed for the exhaust, use a heat resistant hose.
- 5) Install the carbon steel pipe or hose after thoroughly removing rust and dirt from its inside.
- 6) When using sealing tape, be very careful not to let the tape enter the pipes or the pump.
- 7) The pump may be damaged if oil, etc. are sucked in liquid form (including mist).
If such a risk exists, take necessary measures (install an oil separator, etc.) to prevent the entry of oil into the pump.
- 8) If there is a considerable amount of dust in the intake air or if the dust particles are very fine (less than 10 μ), install a suitable filter in addition to the filter supplied with the pump.
- 9) If such a risk as reverse turn of the motor exists on account of residual pressure existing when you stop the pump caused by large length of vacuum pipe or exhaust pipe, install a check valve at the INLET or OUTLET of the pump.

3. OPERATION

- The direction of revolution is indicated by an arrow on the indicator plate. When checking direction of revolution, do not let the pump operate in the reverse direction for a long time.
- The revolutions per minute in the case of CBX15, 25 and 40 are 1,450 r.p.m. for operation on 50Hz and 1,730 r.p.m. on 60Hz (Same r.p.m. as of the 4-pole motor.) and it is, in the case of CBS 62, 1,150 r.p.m. on 50Hz and 1,370 r.p.m. on 60Hz. Never use the pump at any other r.p.m..

(1) Starting

- 1) The most appropriate starting method is to first rotate the vacuum controller and pressure controller fully (toward minus), turn on the power switch, and then set the respective controllers to normal vacuum or normal exhaust pressure after the pump has attained normal operating state.
- 2) When starting after an overhaul or after the pump has been stopped for a long period of time, check that the shaft rotates freely and smoothly.

(2) During Operation

- 1) The operating pressure range is as follows.

Model CBX□, CBS62 Type using V_1 and B_2

V_1 : degree of vacuum, lower than 60 kPa (%—59, inHg—18)

B_2 : exhaust pressure, less than 60 kPa (bar—0.6, psi—8.5)

Model CBX□A, CBS62A Type using V_1 , B_1 , V_2 and B_2

V_1 : degree of vacuum, lower than 55 kPa (%—54, inHg—16)

V_2 : degree of vacuum, lower than 35 kPa (%—34, inHg—10)

B_1 : exhaust pressure, less than 20 kPa (bar—0.2, psi—2.8)

B_2 : exhaust pressure, less than 50 kPa (bar—0.5, psi—7.1)

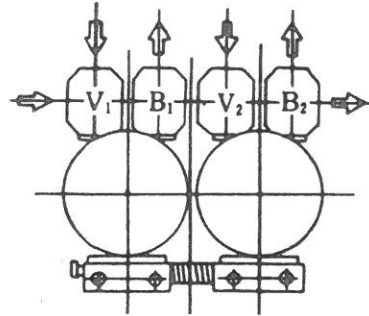

- 2) After continuously operating a pump for a long time, a considerable rise in the pump temperature is normal and is not a matter for concern.

(3) Stopping

- 1) The proper stopping method is to turn off the power switch after adjusting the controllers so that the vacuum gauge and pressure gauge indicate 0, and allowing the inside of the pump to return to atmospheric pressure. If stopped in this manner, next starting can be facilitated.

4. STORAGE

If the pump is to lie idle for an extended period after purchase or after use, store it carefully to prevent rusting.

- (1) Store the pump indoors and place a suitable cover over the pump.
- (2) Select a place where water, oil, etc. will not fall on it.
- (3) Select a dry, clean place.
- (4) Select a well ventilated place (ambient temperature below 40°C).
- (5) Be careful to avoid locations with high temperatures, chlorine gas, sulphurous acid gas and other corrosive gases.

SECTION 3 CONSTRUCTION AND NAMES OF PARTS (TYPE CBX25)

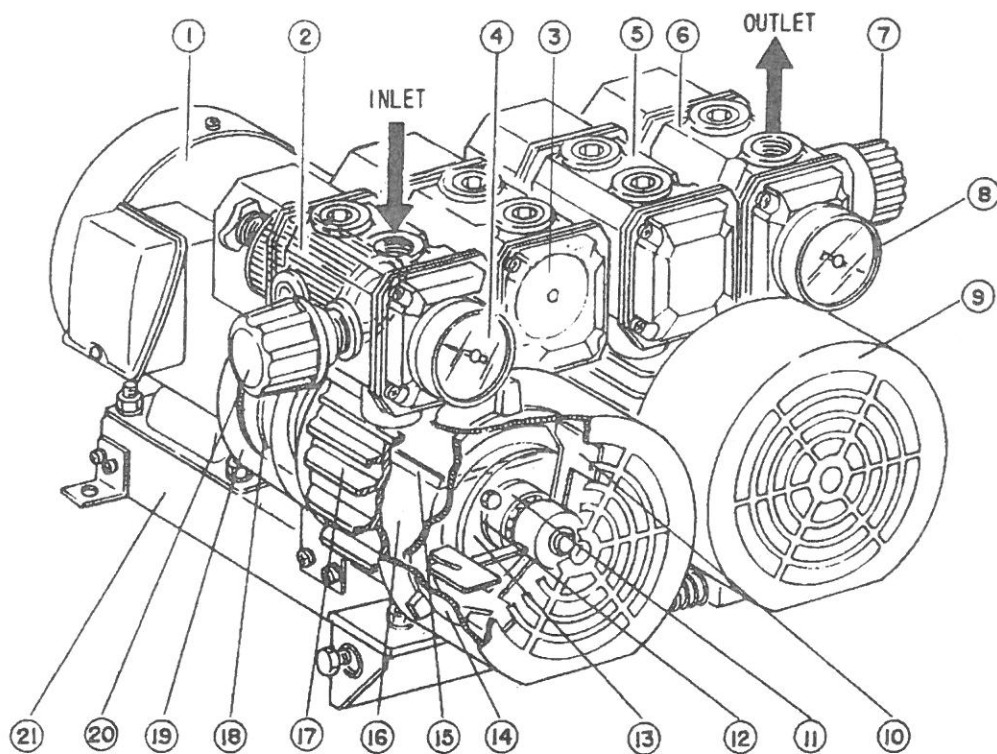

- | | | |
|-----------------------|---------------------|----------------------|
| 1 Motor | 8 Pressure gauge | 15 Blade |
| 2 Filter element | 9 Fan cover | 16 Rotor |
| 3 Covering plate | 10 Cooling fan | 17 Cylinder |
| 4 Vacuum gauge | 11 Bearing | 18 Pulley |
| 5 Suction case | 12 Spacer | 19 Belt cover |
| 6 Delivery case | 13 Bearing retainer | 20 Vacuum controller |
| 7 Pressure controller | 14 Side plate (A) | 21 Base |

vacuum pump functioning process

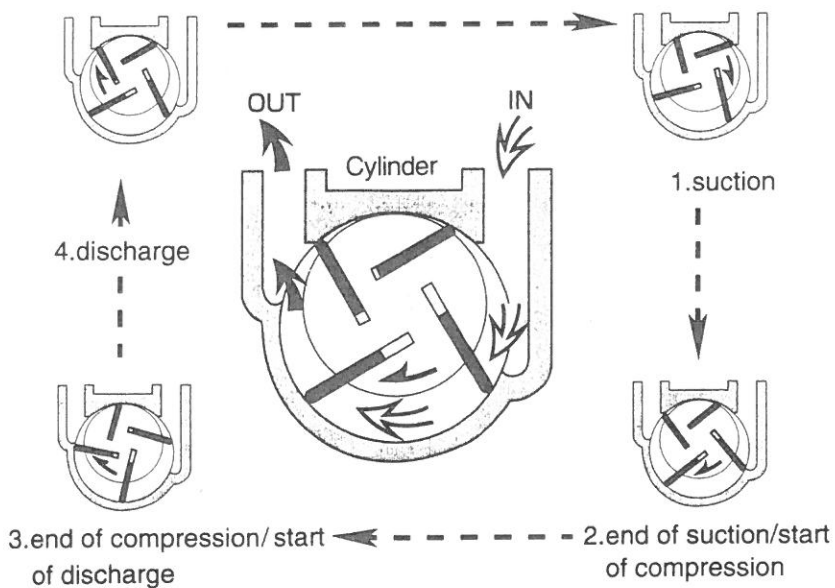

SECTION 4 TROUBLESHOOTING

1. TROUBLE DIAGNOSIS AND REMEDY

To prevent the recurrence of any trouble, completely eliminate its cause(s).

Symptom	Cause	Remedy
A Degree of vacuum or exhaust pressure does not increase.	① Filter element is jammed with dirt and the pump does not suck air.	Detach the element from the unit and remove any dust or dirt, etc. using compressed air or the like. Clean any stains on the element using a neutral detergent, fluorine organic solvent ("Daifron S3") or chlorine organic solvent ("Chlorosen"). Mount the element back into the unit only after it is completely dry. Do not use any of thinners, alcohol, benzene, gasoline or kerosene, etc. for the cleaning as they damage the surface of the element.
	② The blades do not protrude due to the ingress of oil in the pump.	Detach the filter case and muffler from the unit, and pour into the pump, through its suction port or delivery port, a volatile cleaning liquid, i.e. a fluorine organic solvent ("Daifron S3"), chlorine organic solvent ("Chlorosen"). Turn the fan manually to check if it can be turned with ease. After confirming this, set the power switch to "ON" and run the pump to discharge any oil and cleaning liquid contained therein. (If the fan can not be manually turned with ease, allow a few minutes before trying to turn it again.) Take care not to inhale any fumes of the volatile cleaning liquid and, also, ensure that the room is fully ventilated while conducting the cleaning work. Do not use any of thinners, alcohol, benzene, gasoline or kerosene, etc. as the cleaning liquid, as there is a possibility that it may catch fire.
	③ The blades do not protrude due to the entry of foreign matter into the pump.	Remove foreign matter (dirt, dust, etc.) by disassembling the pump.
	④ The pump's inside is rusted due to the entry of moisture and the blades do not protrude.	Disassemble the pump and remove the rust, taking care not to cause scratches.
	⑤ Faulty vacuum gauge.	Replace the defective gauge.
	⑥ Air is leaking due to improper tightening of the filter case, pipes, air tank, etc.	Securely retighten all parts.
	⑦ <ul style="list-style-type: none"> ○ Belt is loose and is slipping. ○ The mounting bolt of the pulley is loose. 	<ul style="list-style-type: none"> ○ Tension the belt again. ○ Retighten the pulley mounting bolt.
	⑧ The revolving speed (rpm) of the pump decreases due to some trouble in the motor.	Repair or replace the defective motor. (Check the voltage and current.)
	⑨ Damaged blade(s).	Disassemble the pump and replace the defective blade(s).
	⑩ Worn blade(s).	Replace the defective blade(s).

Symptom	Cause	Remedy
B Abnormal sound or pulsation of vacuum gauge.	① Abnormal sound is produced due to excessive or insufficient exhaust pressure or vacuum.	Return the exhaust pressure or degree of vacuum to normal.
	② Abnormal sound is produced due to excessively off-centered alignment of pulleys.	Center the coupling properly. Adjust the alignment of pulleys.
	③ Abnormal sound is produced due to burning, etc., of the motor.	Repair or replace the defective motor. (Check the voltage and current.)
	④ Abnormal sound is produced due to loosening of mounting bolts.	Retighten the mounting bolts of all parts.
	⑤ Faulty vacuum gauge.	Replace the defective gauge.
	⑥ Filter element is jammed with dirt, and the pump does not suck air.	Refer to Cause 1 of Symptom A.
	⑦ The blades do not protrude smoothly due to the ingress of oil, etc. in the pump.	Refer to Cause 2 of Symptom A.
	⑧ The blade is damaged due to ingress of foreign matter.	Disassemble the pump, remove the foreign matter and replace the defective blade(s).
C The pump stops rotating.	① The blade is damaged due to ingress of foreign matter.	Disassemble the pump, remove the foreign matter and replace the defective blade(s).
	② The rotor is in contact with the stator due to application of other than the specified pressure.	Disassemble the pump and finish the contact part with sandpaper, or, call in a service man (mechanic).
	③ Faulty electric system.	Check each part system-wire for electrical continuity.
	④ The belt is damaged.	Remove the cause of trouble and replace the belt. When worn belt chips stick to a pulley remove the chips carefully without scratching the pulley.

2. DISASSEMBLY PROCEDURE

Please ask Orion dealer's serviceman to perform assembly and adjustment, which require highly trained skill. If you are obliged to disassemble the pump by yourself, please follow 2. "Disassembly Procedure". The manufacturer's warranty does not cover any damage resulting from the repair made by any person or company other than Orion and its dealers.

The pictures included for illustration apply to Model KRX6, but the disassembly procedure is common to all CBX and CBS models.

Since the assembly and adjustments of the pump require highly advanced technical skill, pump require highly advanced technical skill, please contact your local ORION distributor for repair.

- 1) Take bolts of bearing retainer on both sides off, and remove paper liners and retainer. **NEVER BREAK THE LINERS.** Keep them in order so that they are placed on their original positions when reassembling.

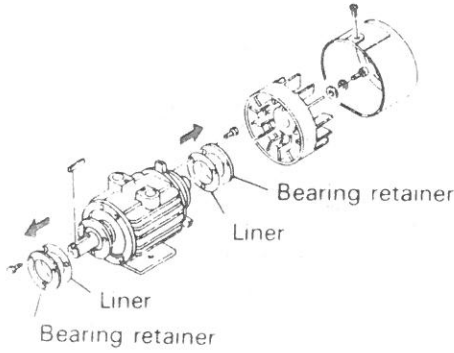

- 2) Remove fastening bolts on side plate B or side plate of motor side.

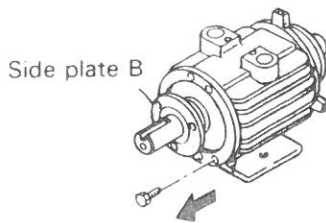

- 3) Fix side plate puller on a bearing retainer with the bolts removed in Procedure 2). Screw them into tapped holes on the bearing retainer.

Be careful **NOT TO INJURE** the inner surface of side plate or of cylinder. It is **NOT RECOMMENDED** to use **OTHER TOOLS** than the **SIDE PLATE PULLER** for taking side plate off.

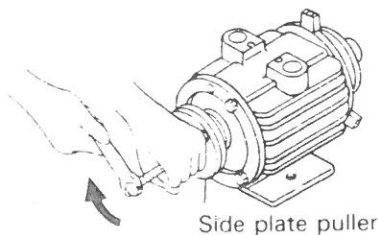

- 4) Keep bearing retainer and liner removed in Procedure 1) attached to side plate B. But **DO NOT TIGHTEN BOLTS** but **LEAVE THEM LOOSE.** (Gap between side plate B and bearing retainer must be about 1 mm.)

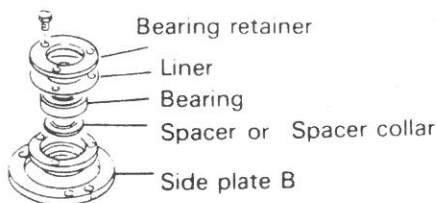

- 5) Take vanes out of pump. **Keep them orderly because they must be put back to their original position.**

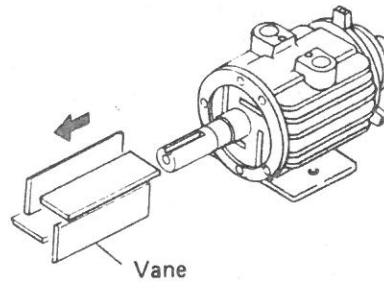

- 6) Push the rotor out from the opposite side of motor using a side plate puller.

Hold the shaft by hand or make the pump stand upright in order to protect the rotor from dropping when taking it out. **Be careful not to INJURE THE ROTOR SHAFT, CYLINDER and other parts.**

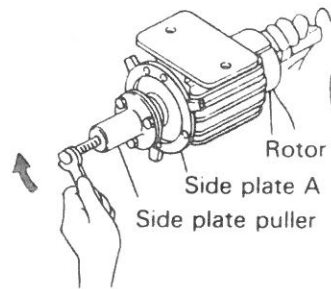

- 7) Take the clamping bolts out of the side plate A on the opposite side of motor. Then remove the side plate A, letting the knock pin loose by screwing the removed two bolts.

Clean each parts with a cloth soaked up with fluorine organic solvent or chlorine organic solvent.

Be careful not to **LET THE BEARING COME IN CONTACT WITH THE CLEANING SOLVENT.** And keep spacers, bearings and side plates in proper order so that they are **TO BE PLACED AT THEIR ORIGINAL POSITIONS CORRECTLY.**

3. ASSEMBLY PROCEDURE

- 1) Make the rotor stand upright, and put side plate A of opposite side of motor, bearing and other parts back to the shaft. Do not forget putting a spacer collar back to its place. But pumps with a staged shaft such as KRX5, 6 do not require a spacer collar.

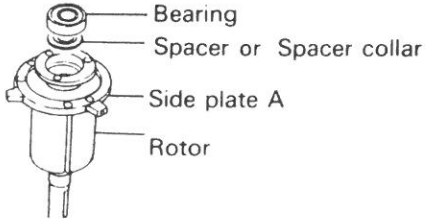

- 2) Knock bearing down with a bearing punch. Use wooden plate or the like as a pedestal in order to avoid injury on the shaft.

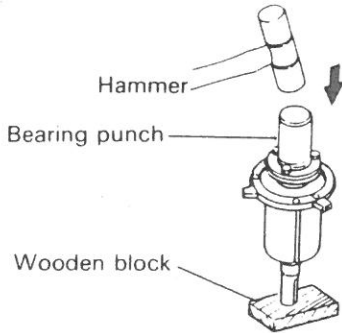

- 3) Restore the assembled rotor into cylinder. **FIX KNOCK PIN CORRECTLY, and TIGHTEN BOLTS. MIND THE DIRECTION OF ROTATION.**

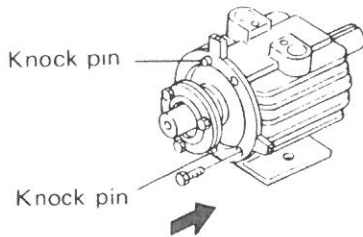

- 4) Insert vanes. **REPLACE THEM AS THEY WERE, PAYING ATTENTION TO THEIR ORIGINAL ORDER and DIRECTION.**

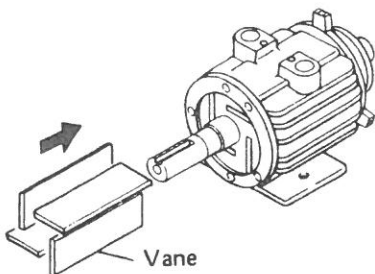

- 5) Reassemble side plate B.
- 6) Fix knock pin correctly, and knock bearing down. Then tighten bolts.

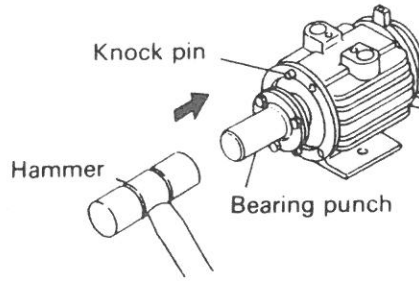

- 7) **Knock BEARING, SPACERS and ROTOR with a bearing punch until all surfaces of these parts come contact tightly.**

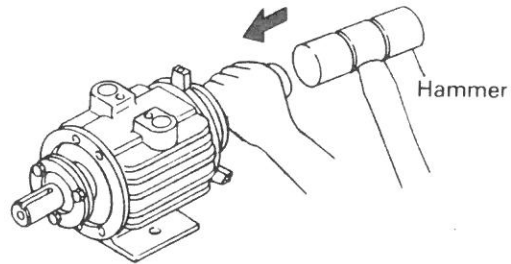

- 8) Tighten bolts of bearing retainer on both sides. The bolts are three on each side.

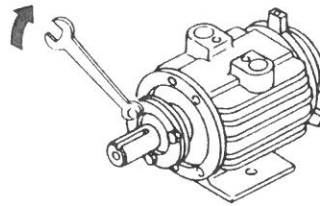

- 9) Confirm result of your servicing. **Rotate the rotor shaft by hand by pushing it or pulling it toward you. And CONFIRM IF ROTOR and SIDE PLATES DO NOT come in contact with each other. You have done it well if they do not touch.**

NOTE: For assembling and disassembling the pump, use the special tools supplied for assembly and disassembly of the dry pump. The special tools are side plate puller, bearing punch and bearing puller.

SECTION 5 PERIODIC INSPECTION

Periodically perform the following inspections according to the extent the pump is used.

1. HOW TO CLEAN THE FILTER

Clean the filter if it has been soiled. By doing so, you can avoid 90 percent of troubles that may otherwise take place.

If the filter is clogged, detach the filter from the unit and remove the substances from it using compressed air.

If the filter is stained, clean the stains using a fluorine organic solvent ("Daifron S3"), chlorine organic solvent ("Chlorosen"), and mount it back into the unit after it is completely dry.

Do not use any thinners, alcohol, benzene, gasoline or kerosene, etc. for the cleaning, as they damages surfaces, etc. of the filter.

Position of filter element

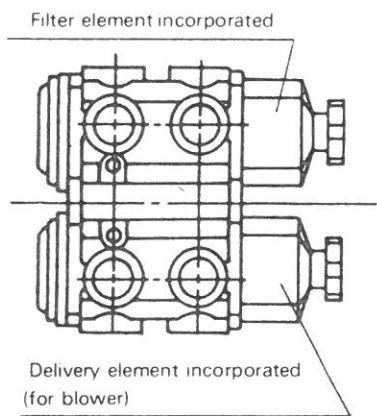

Filter element assembly sequence

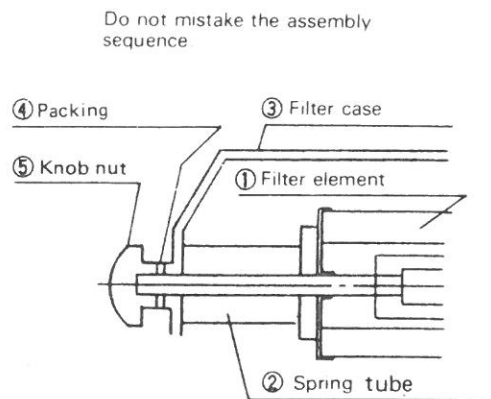

2. CLEANING OF VACUUM CONTROLLER AND PRESSURE CONTROLLER

If the controller's sheet surface is considerably dirty, its function deteriorates. Periodically disassemble each controller and thoroughly clean all parts.

3. INSPECTION OF PIPING

Inspect the piping system for air leakage, blockage, loose joints, etc. Also make sure that the filter case cap is securely tightened.

4. INSPECTION OF PUMP BODY

Disconnect the pipes, etc. from the pump to remove pump with no load and rotate the pump shaft by hand to check whether it rotates easily and smoothly. If the shaft is abnormally heavy, contact your dealer's service department.

If the pump's capacity has deteriorated considerably or if it produces abnormally loud noise, it means that the pump's present service life is nearing its end, so contact your dealer to have the pump overhauled. Heat-resistant bearings used exclusively by our company are employed in this pump, only Orion original spare parts should be used as replacement parts.

5. INSPECTION OF BELT

A compact and durable special belt is equipped, and readjustment of tension is not required.

(1) Time of replacement

1. Replace the belt as necessary according to the result of periodical inspection of wear.
2. Replace the belt when the overhaul such as change of the blade.

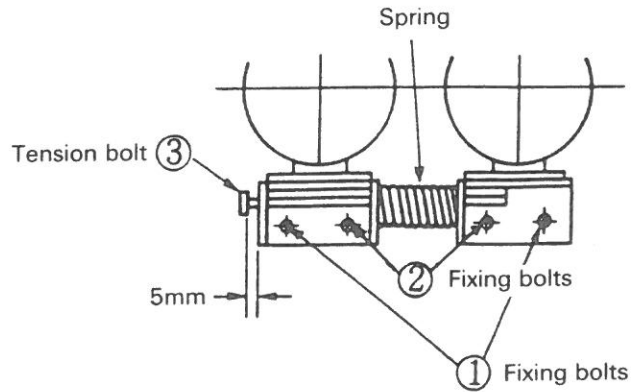

(2) How to replace the belt

Remove the filter case in order to ease servicing,

1. Remove the belt cover.
2. Loosen the four fixing bolts ① ② between a quarter and half rotation.
REMARK : DO NOT LOOSEN THE BOLTS OVER A HALF ROTATION.
3. Turn the tension bolt ③ clockwise until the belt can be removed.
4. Change two belts new ones.
REMARK : REPLACE THE TWO BELTS AT A TIME.
5. Turn the tension bolt anti-clockwise until the space between the tension bolt and base opens 5 mm.
Confirm the belts are stretched.
6. Fasten two inside fixing bolts ② first, then fasten outside ones ①.
REMARK : FASTEN TWO INSIDE BOLTS FIRST.

CAUTION

- Do not loosen the fixing bolts over a half rotation. If the bolts are loosened too much, belts become too taut when bolts are fastened. This can shorten the lifetime of belts considerably.
- Replace the two belts at a time. Due to difference of lifetime of new and old belt, old one can cut earlier and it causes the damage of new one.

(3) Kinds of belt

Model	Kind of belt	Quantity
CBX15	100S5M390	2
CBX25	150S5M390	2
CBX40	200S5M390	2
CBS62, CBX62	200S8M480	2

※Use the Orion genuine belts.

(4) Check on pulley alignment

Poor alignment of pulleys causes shortens the service life time of belt.

Limit the range S of mis-alignment shown in the following figure to less than 0.15mm.

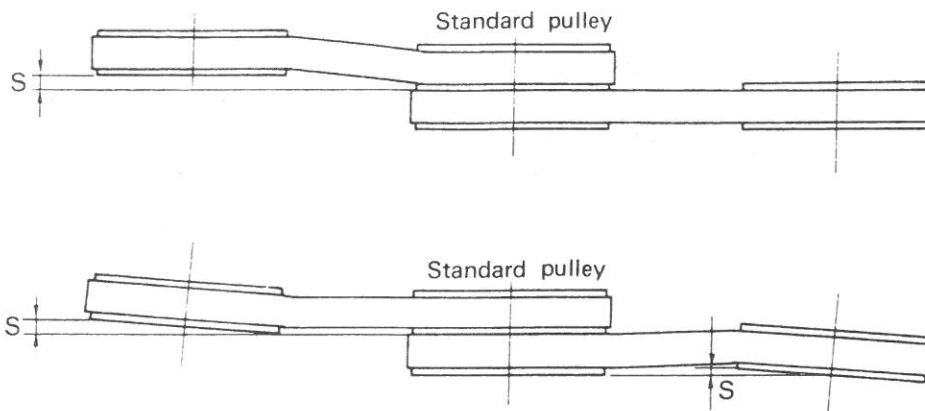

(5) Storage of belts

- 1) Do not store belts in an excessively folded state, or a number of belts stacked over one another.
- 2) Store at normal temperature and avoid direct sunshine.
- 3) Do not hang on a rack or on the wall, nor put them directly on the ground on the floor.
- 4) Do not let oil adhere to belts.

SECTION 6 SPECIFICATIONS

Model	Hertz (Hz)	Design displacement			speed (r.p.m)	Suction/exhaust port diameter(*1)	Motor(*2)	Mass	
		m ³ /h	cfm	L/min				kg	Lbs
CBX15	50	14.1	8.3	235	1,450	Rc3/4	3-phase	39	86
CBX15A	60	16.8	9.9	280	1,730	Female B.S.P.T	0.75 kW 4P		
CBX25	50	24.3	14.3	405	1,450	Rc3/4	3-phase	52	115
CBX25A	60	28.8	17.0	480	1,730	Female B.S.P.T	1.5 kW 4P		
CBX40	50	34.5	20.3	575	1,450	Rc3/4	3-phase	65	143
CBX40A	60	41.1	24.2	685	1,730	Female B.S.P.T	2.2 kW 4P		
CBS62 CBX62 CBS62A CBX62A	50	56.1	33.0	935	1,150	Rc1	3-phase	110	243
	60	66.9	39.4	1,115	1,370	Female B.S.P.T	3.7 kW 4P		

Model	Vacuum pump						Blower pump					
	Max. vacuum(*3)			Max. pressure			Max. vacuum			Max. pressure(*4)		
	%	inHg	kPa	bar	psi	kPa	%	inHg	kPa	bar	psi	kPa
CBX15	59	18	60	—	—	—	—	—	—	0.6	8.5	60
CBX15A	53	16	55	0.2	2.8	20	33	10	35	0.5	7.1	50
CBX25	59	18	60	—	—	—	—	—	—	0.6	8.5	60
CBX25A	53	16	55	0.2	2.8	20	33	10	35	0.5	7.1	50
CBX40	59	18	60	—	—	—	—	—	—	0.6	8.5	60
CBX40A	53	16	55	0.2	2.8	20	33	10	35	0.5	7.1	50
CBS62 CBX62 CBS62A CBX62A	59	18	60	—	—	—	—	—	—	0.6	8.5	60
	53	16	55	0.2	2.8	20	33	10	35	0.5	7.1	50

NOTE: *1 Based on B.S.P. T.

*2 Based on the electric motor to Japanese market.

*3 For vacuum application

*4 For blower application

One pump cannot be used for both applications simultaneously.

CAUTION: Either the maximum vacuum or the maximum pressure attains to the performance larger than the specified value above. But both the operational vacuum and pressure must be kept UNDER the specified value.